

User Manual

For Lithium battery energy storage system



24V200Ah
48V100Ah
51.2V100Ah

Version: 1.0

Table of Contents

1. Introduction	1
2. Important Safety Warning	2
2.1 Before Connecting	2
2.2 During operation	4
3. Unpacking & Overview	4
3.1 Packing List	4
3.2 Product Overview	5
4. Installation	6
4.1 Selecting Mounting Location	6
4.2 Mounting The PACKuccion	7-19
Appendix 1: BMS parameters	19
Appendix 2: Troubleshooting	22
Appendix 3: Emergency process	22-25

1. Introduction

The Energy storage pack is an essential component of the photovoltaic power generation system. It can provide electricity for the connected load, and it can also store photovoltaic solar modules, fuel generators, or wind energy generators by charging the remaining energy in case of emergency. When the sun goes down, energy demand is high, or there is a power outage, you can use the energy stored in the system to meet your energy needs at no additional cost. In addition, the energy storage Pack can help you achieve energy self-consumption and ultimately achieve the goal of energy independence.

According to different power conditions, the energy storage PACK can output power during peak power consumption, and can also store energy during low power consumption. Therefore, when connecting the matching photovoltaic modules or inverter arrays, external equipment is required to match the energy storage the working parameters of the pack to achieve the highest operating efficiency. For a simple diagram of a typical energy storage system.

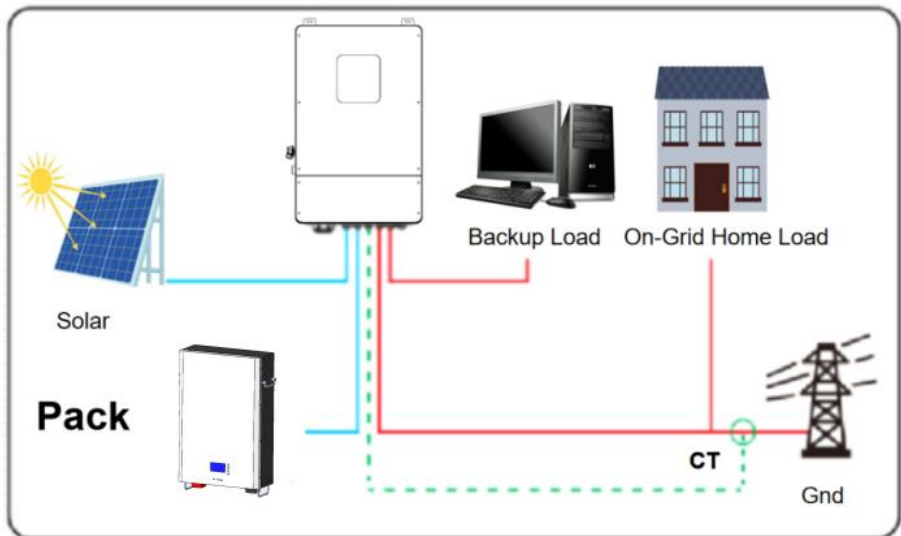

Energy storage System Overview



It is very important and necessary to read the user manual carefully before installing or using the battery. Failure to follow any of the instructions or warnings in this document can result in electrical shock, serious injury, death, or may damage the battery and the whole system.

- If the battery is stored for a long time, it is requirement that they are charged every three to six months, and the SOC should be no less than 80%,after fully discharging,The battery needs to be recharged within 12 hours.
- Do not expose cable outside;Do not use cleaning solvents to clean the battery.
- All battery terminals must be disconnected before maintenance.



2.Important Safety Warning









- Do not expose the battery to flammable or harsh chemicals or vapors.
- Do not paint any part of the battery, include any internal or external components.
- Do not connect battery with PV solar wiring directly.
- Any foreign object is prohibited to be inserted into any part of the battery.
- Our company will not bear any warranty claims for direct or indirect damage caused by violation of the above items.



2.1 Before Connecting

- After unpacking, please check the battery and pack list first, if the battery is damaged or spare parts are missing, Please contact the dealer.
- Before installation, be sure to cut off the grid power and make sure the battery is in the turned-off mode;
- Wiring must be correct, do not mix-connect the positive and negative cables, and ensure no short circuit with the external device;
- It is prohibited to connect the battery with AC power directly;
- The BMS in the battery is designed for 24VDC/48VDC, DO NOT connect battery in series;
It is prohibited to connect the battery with different type of battery;
- Please ensure the electrical parameters of battery system are compatible to inverter;
- Keep the battery away from fire or water.

Necessary installation Tools.

 <p>Multimeter + Current clamp</p>	 <p>Screw Driver Set</p>	 <p>Allen Key Set</p>	 <p>Drill + Hammer</p>
 <p>Electrician Scissors</p>	 <p>Wrench set</p>	 <p>Lifting strap + mechanical lifter</p>	 <p>RS 232/USB+screw terminal (insulated)</p>

Personal protective equipment



2.2 During operation











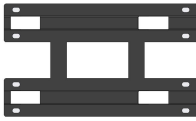

- If the battery system needs to be moved or repaired, the power must be cut off first and the battery is completely shutdown;
- It is prohibited to connect the battery with different type of battery;
- It is prohibited to put the batteries working with faulty or incompatible inverter;
- In case of fire, only dry powder fire extinguisher can be used, liquid fire extinguishers are prohibited;
- Please do not open, repair or disassemble the battery. We do not undertake any consequences or related responsibility due to violation of safety operation or violating of design, production and equipment safety standards.

3 . Unpacking & Overview

3-1. Packing List

You will receive the following parts(Not a full set),sample as follow picture.For customized requirements, please place an order with the manufacturer.

Battery pack 	Mounting brackets 	Power out positive cable 
Power out Negative cable 	Manual *1 	Parallel common cable(RJ45) 
Inverter commoncable(RJ45) 	Mounting frame screw 	Combiner box 
*RS232common box 	*RS485 common box 	

***NOTE :** * Combiner box types of communication tools need to place an order.

3-2. Product Overview

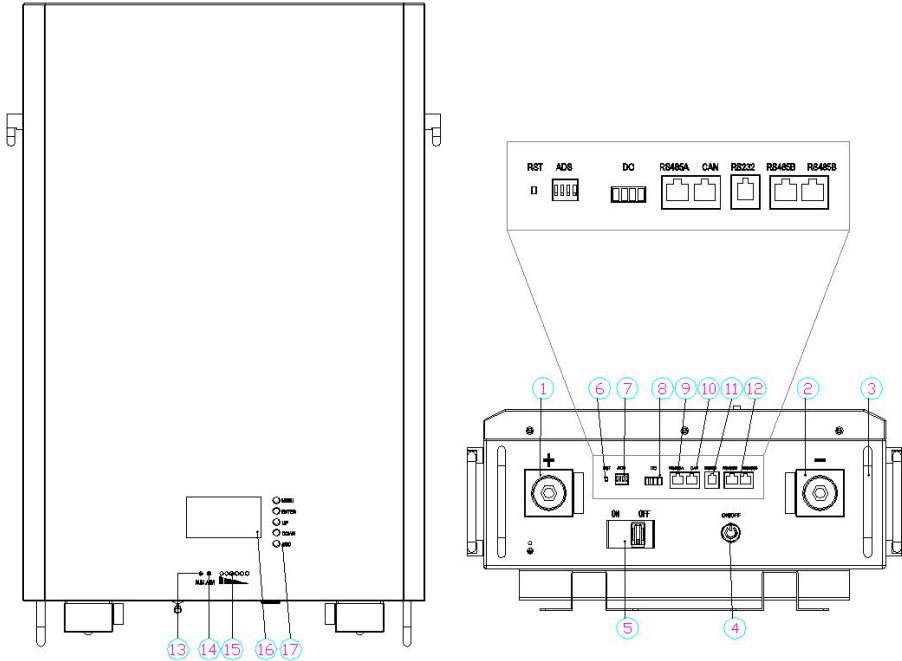

A General battery shape.Front view

No.	Description	Silk-screen	Remark
1	Pack positive pole	P+	Output terminal
2	Pack negative pole	P-	Output terminal
3	handle		
4	E-switch	ON/OFF	
5	Power switch	ON/OFF	
6	Reset button	RST	For reset the batter
7	Dial switch	ADS	Set the address
8	Dry port	DO	
9	RS485A Port	RS485A	RS485A and inverter connection port
10	CAN bus Port	CAN	CAN bus and inverter connection port
11	RS232 Port	RS232	RS232 and computer connection port
12	RS485B Port	RS485B	battery and battery connection port
13	LED indicate	RUN	Operation indicator

14	LED indicate	ALM	Alarm indicator
15	LED indicate	CAPACITY	Capacity indicator
16	LCD		
17	LCD Key	MENU/Enter/Up /DOWN/ESC	

Combiner control box:4 port IN,4 port out .

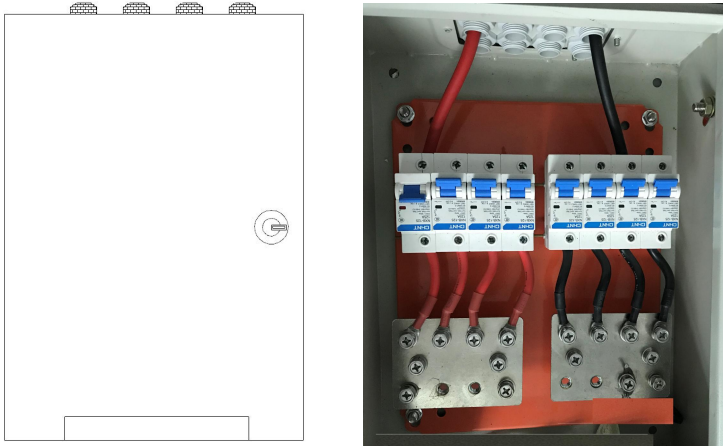

Combiner control box

4.Installation

4-1. Selecting Mounting Location

Consider the following points to install the energy storage Pack:

- Do not mount the Pack on flammable construction materials.Mount on a solid surface;
- Install this Pack module at eye level in order to allow the readability of LCD display at all times.
- For proper air circulation to dissipate heat, please leave a gap of about >0.3 meter from the ground,30 cm from the side of the device.
- The ambient temperature should be between 0°C and 40°C and relative humidity should be between 25% and 85% to ensure optimal operation.
- The recommended installation is Vertical adherence.
- Install the battery module in a dry, protected area with no excessive dust and sufficient air circulation. Do not operate in locations where the temperature and humidity are outside the specified range.

4-2. Mounting The PACK



WARNING!! Remember that this Pack is heavy so please be careful when removing it from the package, or install it .

When installing the Pack bracket, use appropriate screws to fix it. After that, the equipment should be firmly bolted. The pack can be run indoors or outdoors. However, only professional personnel can enter this area for installation or maintenance.

Step 1:

When receiving the product, first check whether all parts are complete, if not, please report to the Dealer .

Step 2:

Ensure that the Pack is installed on the wall surface. Choose a suitable installation location and require the battery pack to be placed at a safe distance greater than 30cm from the ground, and the safety distance between battery packs is also greater than 30cm too. We recommend an installation distance is 50cm.

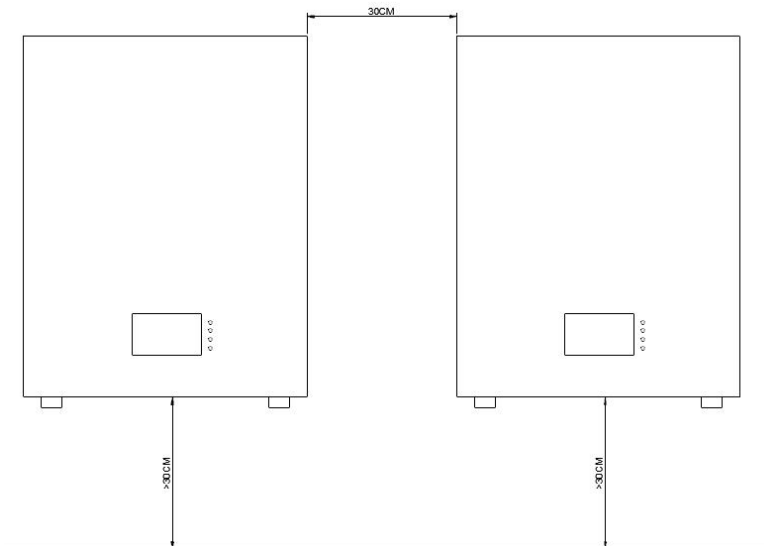

Step 3:

Use the mounting bracket to mark the location of the positioning screw hole on the wall, and use an electric drill to drilling the hole. Need to be drilled with a drill of appropriate diameter.

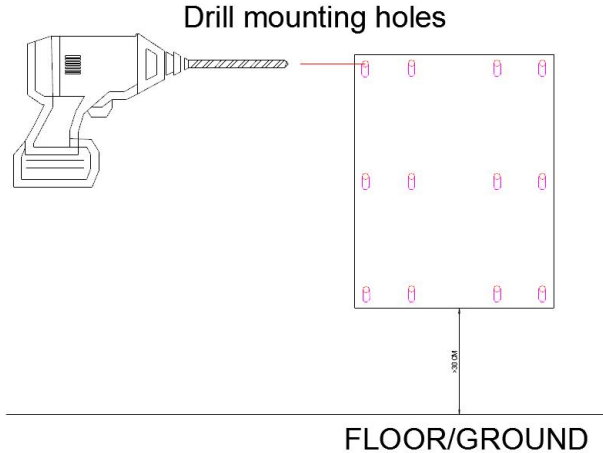

Step 4:

insert frame screws, then place the bracket, and use screws lock it .

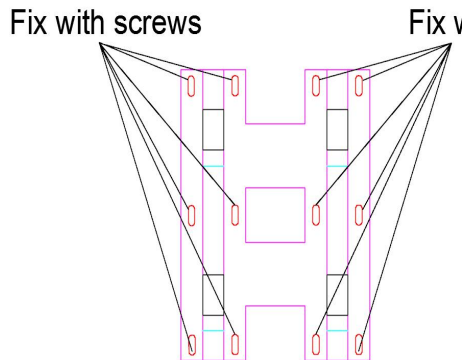
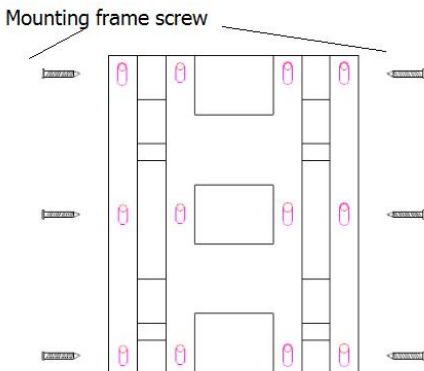

Step 5:

As shown in the below, install the battery pack. The pack is too heavy , Please use a special lifting device to lift the pack for operation and safety protection.Lift the pack and put it into the slot of the fixing bracket from the front.you can install more packs as shown.

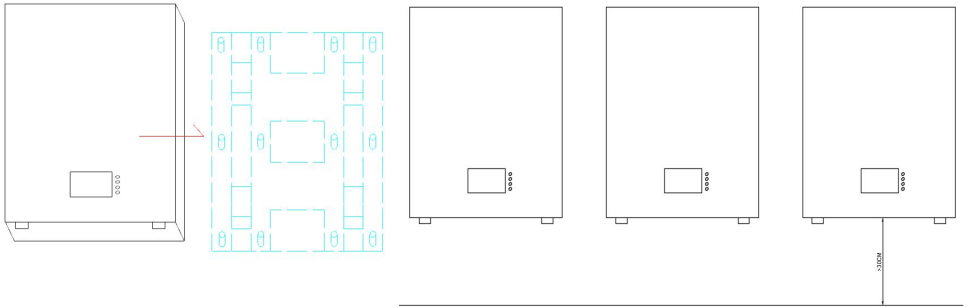

Step 6:

When more than 3 PCS packs are connected in parallel ,then we recommend you install combiner box. 4 locations we recommend you install the combiner box.First select location is Top and Bottom .

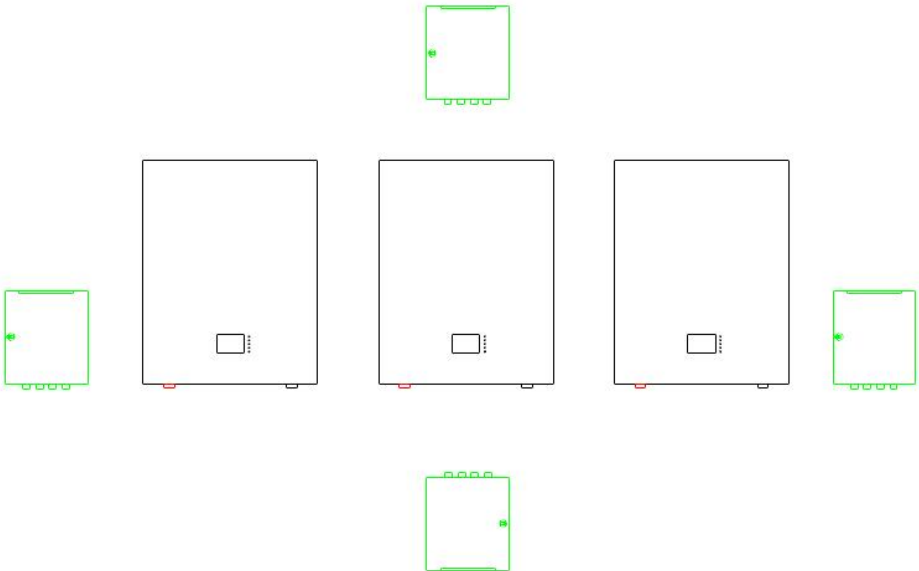

Step 7:

Connect the wiring of the Pack as shown below. see figure 11. If inverter need CAN BUS port /RS485 port. please insert communication cable (RJ45) to CAN port or RS485A, RS485B only be used for battery packs parallel mode.

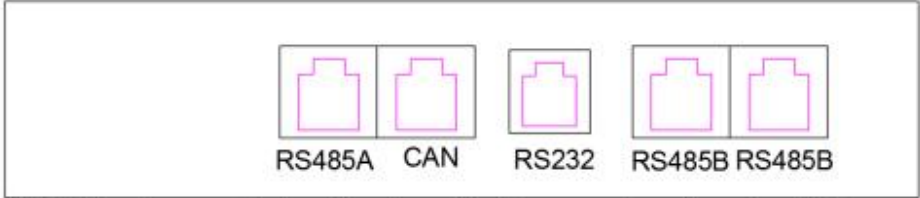

RS485A---Communicate with external devices, sample as inverter ,EPS

CAN

RS232----Communication with host computer

RS485B---Communication with host computer or parallel communication with battery pack

1pack---1 Inverter. Single mode .

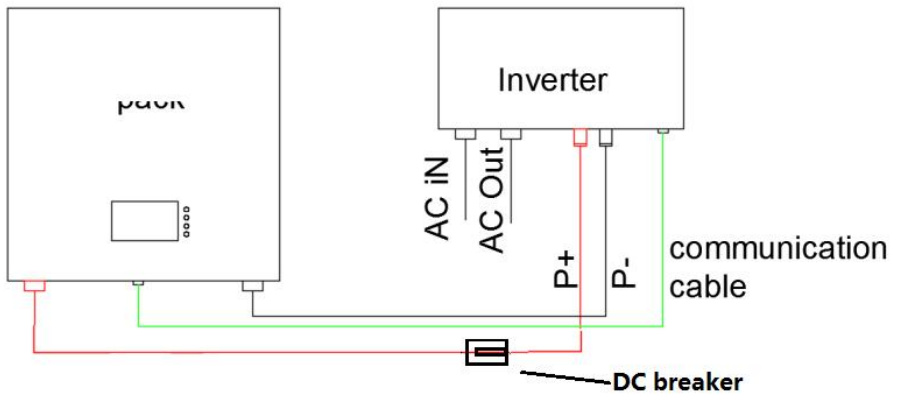

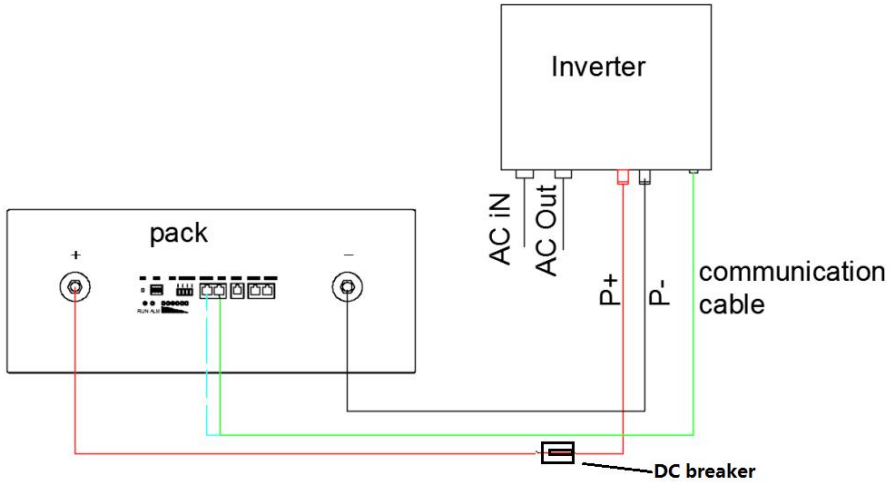

2 pack---1 Inverter. Pack 1 is slave ; pack 2 is master; Negative and Positive power cable has the same length.

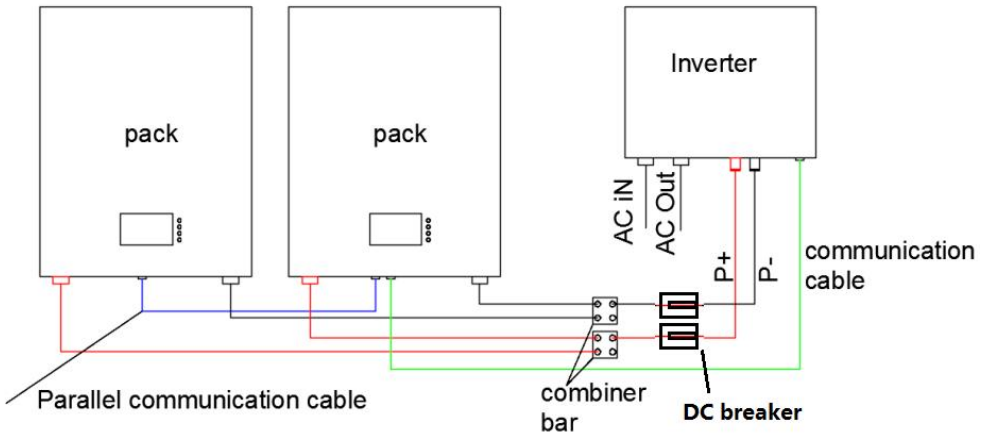

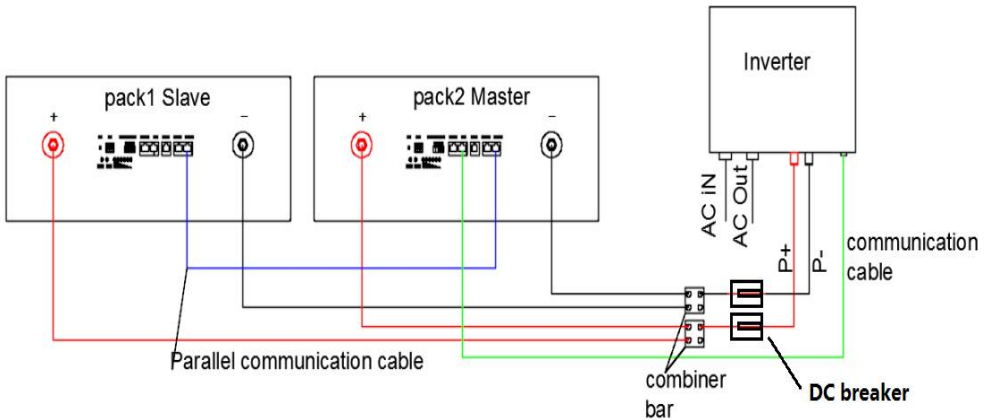

3 pack---1 Inverter. Pack 1 ,2 is slave ; pack 3 is master.more pack are parallel,one pack is master,other are slave.Negative and Positive power cable has the same.

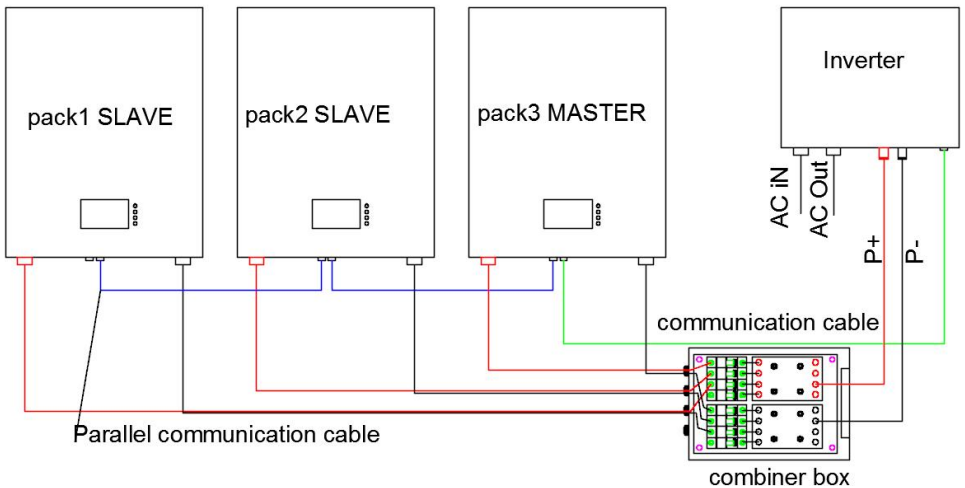

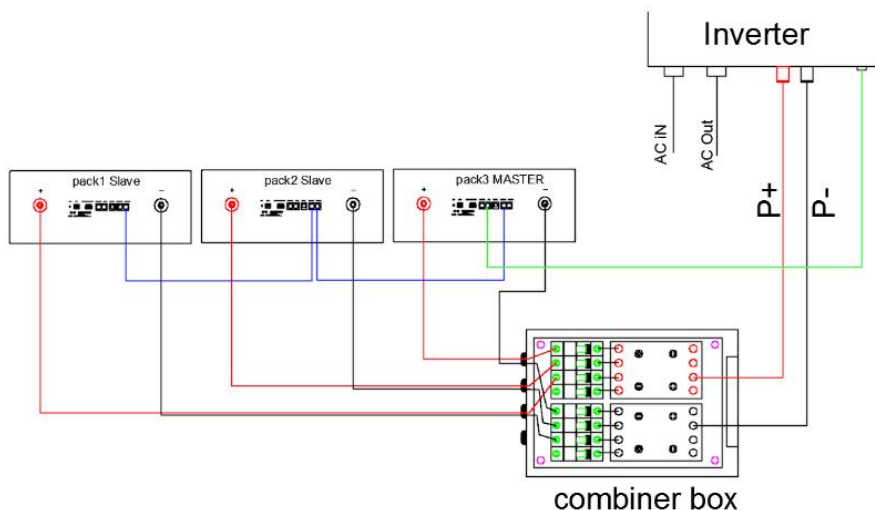

3 pack---3 Inverter. Mainly wiring for 3-phase inverter.Pack 1 ,2 is slave ; pack 3 is master.more pack are parallel,one pack is master,other are slave. 3-phase inverter output 380VAC.one inverter is master,other are slave .Please refer to the operation manual of the inverter for the parallel connection method of the inverter, there is only an example.

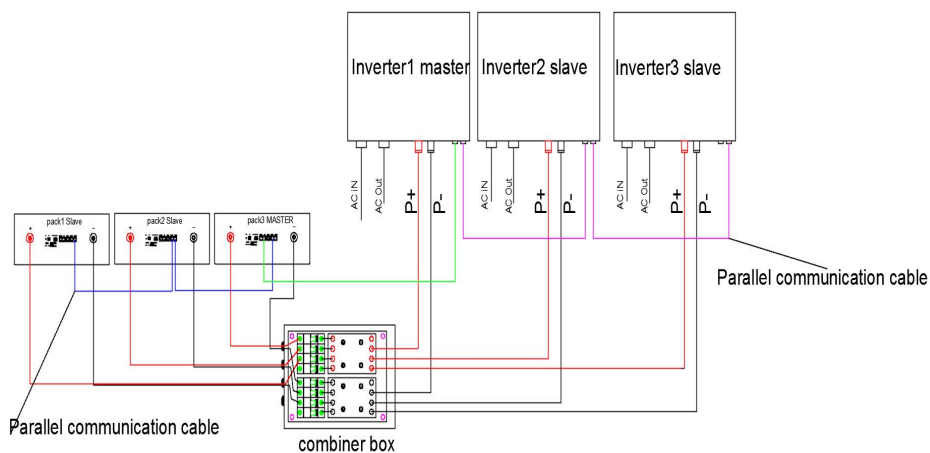

Step 8:

Set the address of pack.this a important step,you can see there is 4bit or 8bit coder in bottom of Pack.please set as bill 1 and 2.

4 bit CODER: this is Binary CODER,Calculated by 8 4 2 1 BCD code.PACK 1 set as Master(BCD 1 0 0 0),see bill1.It support 15 PCS pack(max) in parallel.Address "0" is only used for single mode.

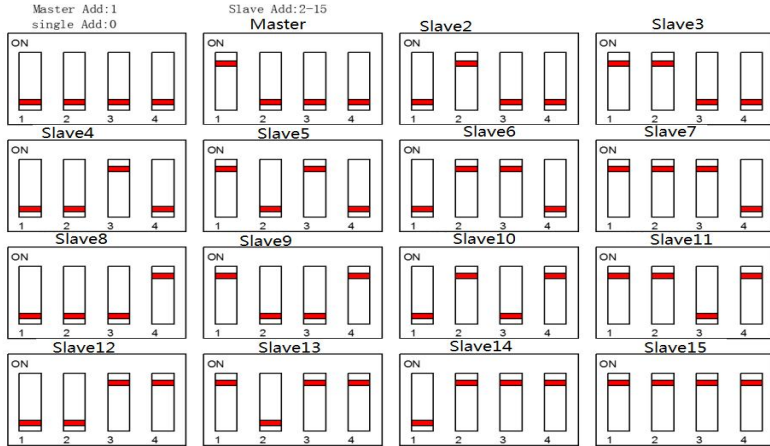

this is 4bits coder and communication port.CAN port and RS485A port can be selected as the same time.

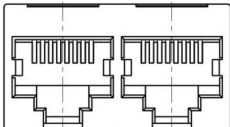
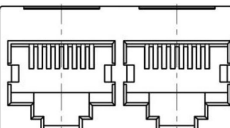

Parallel communication		RS485B-8P8C		RS485B-8P8C		
		RJ45		RJ45		
		1,8	RS485-B	9,16		RS485-B
		2,7	RS485-A	10,15		RS485-A
		3,6	GND	11,14		GND
		4,5	NC	12,13	NC	
External communication		RS485A port		CAN port		
		RJ45		RJ45		
		1,8	RS485-B1	9,10,11,14,16		
		2,7	RS485-A1	12		CAN-L
		3,6	GND	13		CAN-H
		4,5	NC	15	GND	

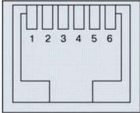
Communication with host computer		RS232		RJ11	
		RJ11		RJ11	
		1	NC	4	RX
		2	NC	5	GND
		3	TX	6	NC

NOTE:The output connected to the communication cable with a waterproof plug is listed according to the order requirements, which are customized products, and are not listed here.

Step 9:

Connect the parallel communication cable (yellow network line).Any Pack has 2 PCS RS485B port for parallel communication, 1 PCS RS485A and 1PCS CAN port for inverter or other device.RS232 port only used for host software and update the firmware.

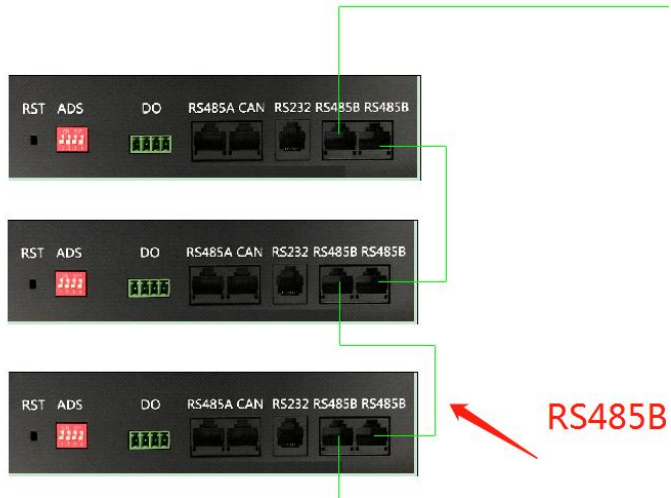

Step 10:

Start and stop battery pack.Confirm that the operation is correct, and the battery function can be turned on after the wiring is correct ,and You can press down power switch(ON/OFF) 3 second for start battery pack,then turn on switch in the combiner box , the battery start working and output ,it enter standby mode(if there is no power switch,please use a little pole and press down the RESET key 3-6second,like as follow picture,LED indicate all running status and check it's self).



Note: You need to turn on the low side switch first(Discharge negative); then turn on high side(Discharge positive),if any of pack has mistake or alarm,you'd turn off the switch which connect to this pack,check and reset the pack ,then turn on switch again.Turn off the pack ,you must turn off the high side switch,then turn off low side switch.

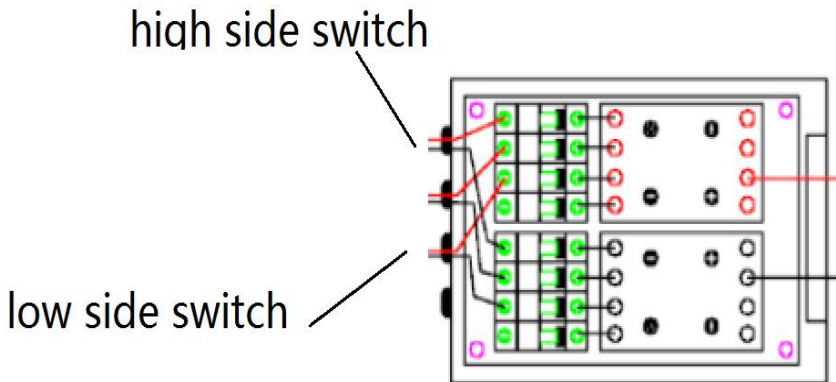

Step 11:

Running the device, set the external charger or inverter parameters, please set according to the corresponding operation manual.Can not exceed the rated parameter requirements .

Battery Pack parameters:

No	Item	General Parameter		
1	Combination method	24V	48V	51.2V
2	Rated Capacity(Ah) (typical)	100/200	100/	100
3	Factory Voltage(V)	25.6-26.4V	48-50V	51-53V
4	Rate power(Wh)	2560/5120	4800	5120
5	Charging Voltage(V)	28/28.8V	54/54.6V	57/57.6V

	recommend/max			
6	Charging Current(A) recommend/max	0.2C/0.5C	0.2C/0.5C	0.2C/0.5C
7	Float charge Voltage(V)	27.6V	53.5V	55.5V
8	Discharge Cut-off Voltage(V)	≤22V	≤41V	≤44V
9	Max Discharging current(A)	0.5C		
10	Charging Current limits(A)	10A/20A		
11	Charge over Current protect(A)	110/Adjustable		
12	Discharge over Current protect(A) Adjustable	110A		
13	Internal Impedance	≤100mΩ		
14	Communication protocol	CAN/485	CAN/485	CAN/485
15	Host software and Communication protocol	RS232/485	RS232/485	RS232/485
16	Operation Temperature Range	Charge:0~55℃		
		Discharge: -20~55℃		
17	Storage Temperature Range(recommend)	0℃~25℃		

Battery Pack parallel parameters:

No	Item	General Parameter		
		24V	48V	51.2V
1	Combination method	24V	48V	51.2V
2	Rated Capacity(Ah)*Parallel	PACK *Parallel	PACK *Parallel	PACK *Parallel
3	Factory Voltage(V)	25.6-26.4V	48-50V	51-53V
4	Charging Voltage(V)recommend/max	28/28.8V	54/54.6V	57/57.6V
5	Charging Current(A)recommend/max	0.1C/0.2C (total)	0.1C/0.2C (total)	0.1C/0.2C (total)
6	Float charge Voltage(V)	27.6V	53V	56V
7	Discharge Cut-off Voltage(V)	≤24V	≤48V	≤50V
8	Max Discharging current(A)	90*Parallel/150*Parallel/180*Parallel		
9	Charging Current limits(A)	10A/20A*Parallel		

10	Charge over Current protect(A)	110/110/Adjustable*Parallel		
11	Discharge over Current protect(A) Adjustable	110/110/Adjustable*Parallel		
12	Internal Impedance	≤100mΩ	≤100mΩ	≤100mΩ
13	Communication protocol	CAN or 485	CAN or 485	CAN or 485
14	Host software and Communication protocol	RS232/485	RS232/485	RS232/485
15	Operation Temperature Range	Charge:0~50℃		
		Discharge: -20~55℃		
16	Storage Temperature Range(recommend)	0℃~25℃		

Battery Pack support communication with inverter:(More communication protocols need to be proposed separately)

NO.	Specification						
1	SMA						
2	MUST						
3	Victron						
4	Schneider						
5	DeYe						
6	Growatt						

Step 12: Monitor all running status,and record all parameters,if there has any mistake,please record it .After start the system,every pack is on ,and led indicate these status.

Step 13:Stop running battery pack.

When it is necessary to stop the charging and discharging of the battery or troubleshooting, please stop the external equipment first, cut off the input and output circuits, and then press the power switch off each battery pack.

Appendix 1

BMS parameters.

LED indicate ,picture of 4bit coder.

Chart 1: Battery Status



SOC						ALARM	RUN

Chart 2: Battery Capacity

status	charge					discharge						
SOC(%)	L6	L5	L4	L3	L2	L1	L6	L5	L4	L3	L2	L1
0-16.6%	OFF	OFF	OFF	OFF	OFF	Flash 2	OFF	OFF	OFF	OFF	OFF	light
16.6-33.2%	OFF	OFF	OFF	OFF	Flash 2	light	OFF	OFF	OFF	OFF	light	light
33.2-49.8%	OFF	OFF	OFF	Flash 2	light	light	OFF	OFF	OFF	light	light	light
49.8-66.4%	OFF	OFF	Flash 2	light	light	light	OFF	OFF	light	light	light	light
66.4-83%	OFF	Flash 2	light	light	light	light	OFF	light	light	light	light	light
83-100%	Flash 2	light	light	light	light	light	light	light	light	light	light	light
RUN LED	light					Flash(flash 3)						

Chart 3: LED flash and buzzer mode(Off by default)

MODE	ON	OFF	MODE	ON	OFF
Led Flash1	0.25S	3.75S	Buzzer1	0.25S	0.25S
Led Flash2	0.5S	0.5S	Buzzer2	0.25S	2S
Led Flash3	0.5S	1.5S	Buzzer3	0.25S	3S

Chart4: LED flash mode

System status	Run status	ON/OFF	RUN	ALM	SOC						REMARK

Power off	SLEEP	OFF	OFF	OFF	OFF	OFF	OFF	OFF	OFF	OFF	OFF	All led off
Stand by	NORMAL	Light	Flash1	OFF	Lighting for SOC						stand by mode	
	ALARM	Light	Flash1	Flash3							Low volt alarm	
CHARGE	NORMAL	Light	Light	OFF	Lighting for SOC(The LED flash2,while it is the high SOC)Alarm LED do not flash,when the BMS into OVP mode.							
	ALARM	Light	light	Flash3								
	OVP	Light	Light	OFF	Light	Light	Light	Light	Light	Light	No charge in,into standby	
	OTP,OC P,Fail	Light	OFF	Light	OFF	OFF	OFF	OFF	OFF	OFF	OFF	Stop charge
Discharge	NORMAL	Light	Flash3	OFF	Lighting for SOC							
	ALARM	Light	Flash3	Flash3								
	UVP	Light	OFF	OFF	OFF	OFF	OFF	OFF	OFF	OFF	OFF	Discharge off
	OTP,OC P,SCP,Fail	Light	OFF	Light	OFF	OFF	OFF	OFF	OFF	OFF	OFF	Discharge off
FAIL		OFF	OFF	Light	OFF	OFF	OFF	OFF	OFF	OFF	OFF	NO Charge or discharge

Chart5: LCD screen display.

.1 Display rendering



.2 Main menu page

After BMS is activated, will show the welcome screen, press the “MENU” button to enter the main menu page. As shown in the figure below:

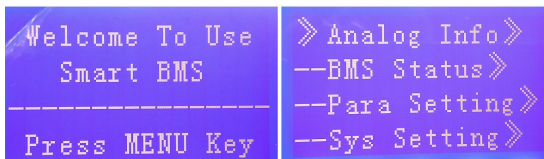

.3 Battery parameters page

When the cursor“>>” is point to “Battery Parameters Acquisition”, press “ENTER” key will enter the page of“Battery Parameters Acquisition”, As

shown in the figure below:

```

>>PackV: 53.22 V --T1: 26.1℃ --PCB_T: 27.4℃
--Im: 0.00 A --T2: 26.2℃ --ENV_T: 27.4℃
--Temperature>> --T3: 26.6℃
--Cell Voltage>> --T4: 26.2℃

--Cell101: 3333 mV >>CellCapacity>> SOC: 0.00 %
--Cell102: 3333 mV FCC: 50.0AH
--Cell103: 3331 mV Rm : 0.0AH
--Cell104: 3329 mV CC : 0

```

When the cursor “>>” is point to “Battery Status”, press “ENTER” key will enter the page of “Battery Status”, As shown in the figure below:

```

>> Status: Idle >> OVP: 0 >> UV : N
--Record>> --UVP: N
--BMS Status>> --OC: N
--OCP: N

>> SCP: 0 >> SCP: N >> OT : N
--O/UTP: 0 --Failure: N --OTP: N
--OCP: 0 --OV: N
--UVP: 7 --OVP: N

```

Parameter Settings

Screen can not set parameters Baud Rate: 9600 ,Can not be set.

```

--Non-production
manufacturer can
not use.

--Baud rate:9600

```

Key description

1) SW1----MENU, SW2----ENTER, SW3----UP, SW4----DOWN, SW5----ESC.

2) Each item is “>>” or “--” as a beginning, among them “>>” shows the current cursor position, press “UP” or “DOWN” key can move the cursor position; with “>>” end of the project, the content of the

said project has not shown, press “ENTER” key can enter the corresponding page.

3) Press “ESC” key can be returned at the next higher level directory; In any position, press” MENU” key can return to the main menu page.

4) when BMS inter sleep mode, press any key, can activate the screen.

Inter standby mode , with no keystrokes 1 minutes later, LCD will enter Shutdown mode press any key,screen can be activated.

Appendix 2

Host soft operation:

The screenshot displays the PbmTools V2.5FN software interface. At the top, a file explorer window shows the software's location: C:\Downloads\PbmTools V2.5FN. The main application window has several tabs: Realtime Monitoring (selected), Multi Monitoring, Memory Info., Parameter Setting, System Config., and Export Datas. Below the tabs is a channel selection bar with buttons 1 through 15. The interface is divided into several sections:

- Pack Information:** Fields for Pack Voltage (V), Pack Current (A), SOC (%), SOH (%), RemainCapacity (mAh), FullCapacity (mAh), and Battery Cycle.
- Temperature:** Fields for MOS_T (°C) and ENV_T (°C).
- Cell Voltage(mV):** A grid of 16 input fields for individual cell voltages (Vocell 1 to Vocell 16).
- Serial Port:** Settings for port, Baud Rate (9600), Pack Qty (1), and Interval (s) (1). Buttons for 'Open' and 'Try Connect' are present.
- System Status:** Radio buttons for CHARGING-OFF, CHARGING, CHG-LIMIT-OFF, DISCHARGING-OFF, DISCHARGING, and HEATER-OFF.
- Alarm Status:** A green bar indicating the current alarm state.
- Protect Status:** A green bar indicating the current protection status.
- Fault Status:** A green bar indicating the current fault status.
- Switch Control:** Buttons for HG Circuit (Open), Sound Alarm (Open), SG Circuit (Open), LED Alarm (Open), and Shutdown (Off).
- Bottom Bar:** Fields for Password, Change, and Clear.

Appendix 3

Troubleshooting

1 battery pack stop work.

A:turn on switch,be sure it is ON;if battery is low SOC.it need to charging in.

B:Battery pack low volt or enter sleep mode,there you will press down “RST” button3-6 second,or charging in.



2 No communication ,inverter can not received any DATA from BMS.

A :Check whether if communication cable is OK,check RJ45 PIN ,

CAN :PIN4:CANH,485A-A,

PIN5:CANL; 485A-B

RS485A:PIN2:485A-A,

PIN1:485A-B;

B: Replace the communication line.Please give feedback to the dealer and exchange it.

C:Check inverter or other device which connect to BMS,update it is firmware.

D:If the communication function needs to be upgraded, please consult the agent or manufacturer.

E: confirm your inverter and battery protocol is correct,Different protocol or different connection will make a mistake.

3 Battery pack report SOC is mistake.

A:inverter received Data from Master BMS ,but it is SOC <total SOC,sample as :9PCS packs has 1800Ah,but inverter read DATA is 1600Ah.So you may check any one is disconnected.check RS485B communication cable(yellow),RS485 communication cable ,replace the cable which is broken.RJ45 PIN:

CAN : PIN4:CANH,

PIN5:CANL;

RS485A: PIN2:485-A,

PIN1:485-B;

B: SOC DATA has Large tolerance.

Discharge empty the battery first, then charge it fully with a small current, and learn to discharge. Any pack is mistake, we advise you read the BMS Data (When we authorize the terminal to use) with host software. then we reset the BMS and calibration.

C: When multiple batteries are connected in parallel, the SOC is different.

We recommend that each pack has a small current discharged and it is emptied until the SOC alarm appears, and then recharged in parallel and fully charged.

4 How to turn on the Pack to discharge.

we recommend method is :

A: reset the single pack's BMS, LED will flash and start work

B: turn on the power switch on the bottom/front panel;

C: turn on power switch in the combiner box .

 **WARNING:** The operating parameters of the equipment cannot exceed the rated working voltage and current of the Pack, exceed the rated volt and current, Can cause damage to the Pack or other failures.

5 Inverter or other external device can not connect the battery.

we recommend method is :

A: Check whether the working parameters of the device and battery are appropriate, and improper parameters cannot be matched.

B: When the device is turned on, the current is too large, resulting in battery protection. At this time, you should be able to see the LED flashing from the battery panel. In this case, You can adjust your equipment parameters or contact the dealer to solve.

C: it is necessary to update BMS parameters and match the device, then Reset BMS and restart your device.

6 Replace bad Pack.

There is a bad battery pack, it is need to replace, please connect your supplier, need professional installers to operate it. We recommend replace all or make pack has same voltage and same specification batteries pack.

NOTE: When replacing the battery, the same module needs to be replaced at the same time, and the voltage should be the same.

7 Need to replace spare parts or emergency maintenance.

Some parts can be obtained from the sales or agency, and the excess parts need to be purchased separately. Be careful, turn off the power switch before replacing parts.

8 Need to place some safety device for keep a safe environment.

You'd keep a safe case for Pack and external device, Please place safety device , as :fire-fighting sand, fire-fighting blankets, fire-fighting water pipes ,

Install Monitor sound, light, electricity, smoke and other equipment.

WARNING:

Emergency process:

1 .The external device catches fire and explodes:

A: Under the condition of ensuring safety, non-operating personnel immediately move to a safe location;

B: Under the condition of ensuring safety, the operator immediately cut off the external power supply of the equipment and the internal power supply.

C:Use fire-fighting equipment for fire-fighting treatment (the use of fire-fighting sand, fire-fighting blankets, fire-fighting water pipes)

D:If you cannot completely extinguish the fire, please call the local fire department for help.

E:Keep the accident site data so that the source of the accident can be traced.

2 .The Pack catches fire and explodes:

A: Under the condition of ensuring safety, non-operating personnel immediately move to a safe location;

B: Under the condition of ensuring safety, the operator immediately cut off the external power supply of the equipment and the internal power supply.

C:Use fire-fighting equipment for fire-fighting treatment (first the use of fire-fighting sand, fire-fighting blankets, then fire-fighting water pipes for cool the Pack)

D:If you cannot completely extinguish the fire, please call the local fire department for help.

E:Keep the accident site data so that the source of the accident can be traced.